

# Ambi-Dry Verge 9550/9601 - Fixing Instructions

Suitable for Mini Stonewold\*, Landmark Double Pantile, Landmark Double Roman, Grovebury, 50 Double Roman, Regent, Renown

## Ambi-Dry Verge Bag Contents

- 10 Ambi-Dry Verge Units
- 10 Batten End Clips
- 10 Stainless Steel Nails 65mm x 3.35mm dia
- 20 Stainless Steel Nails 20mm x 2.65mm

## Eaves/Ridge Pack Contents

(available separately)

### Product Code 9552/9602

- 1 Eaves Closure Unit
- 1 Ambi-Dry Eaves Clip
- 1 Ridge Comb Unit
- 2 Stainless Steel Annular Ring Shanked Nails 55mm x 2.65mm dia
- 2 Stainless Steel Pan Head Self-Tapping Screws 3/4" x 8 Gauge.

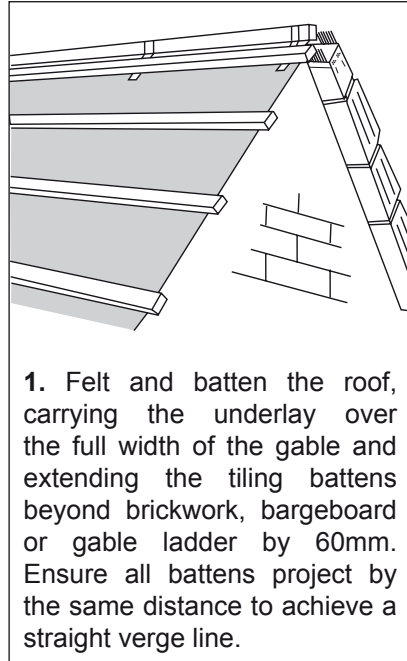

**1.** Felt and batten the roof, carrying the underlay over the full width of the gable and extending the tiling battens beyond brickwork, bargeboard or gable ladder by 60mm. Ensure all battens project by the same distance to achieve a straight verge line.



**2.** Using the 20 x 2.65mm dia. nails provided, fix a Batten End Clip to each tiling batten.

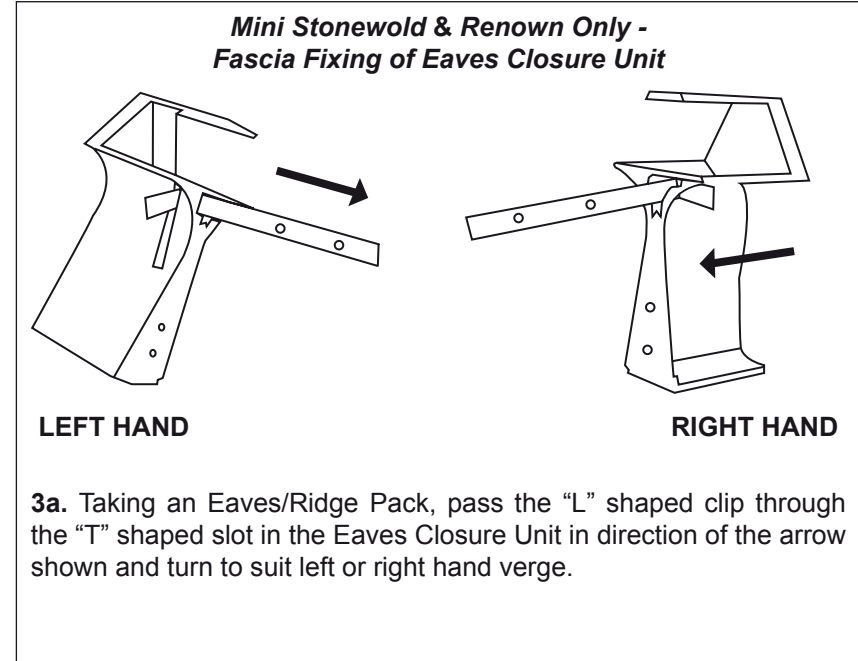

## Mini Stonewold & Renown Only - Fascia Fixing of Eaves Closure Unit

**LEFT HAND**

**RIGHT HAND**

**3a.** Taking an Eaves/Ridge Pack, pass the "L" shaped clip through the "T" shaped slot in the Eaves Closure Unit in direction of the arrow shown and turn to suit left or right hand verge.

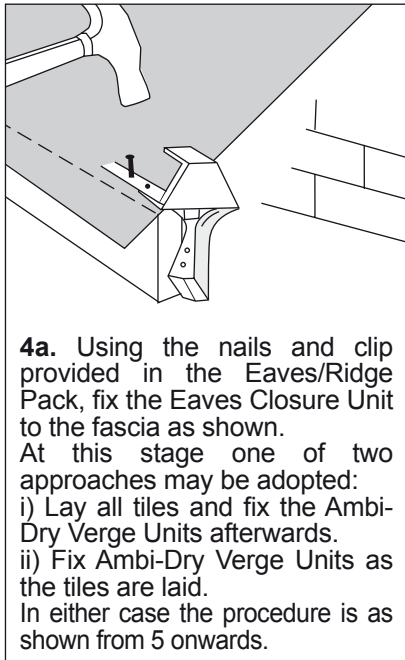

**4a.** Using the nails and clip provided in the Eaves/Ridge Pack, fix the Eaves Closure Unit to the fascia as shown. At this stage one of two approaches may be adopted:  
i) Lay all tiles and fix the Ambi-Dry Verge Units afterwards.  
ii) Fix Ambi-Dry Verge Units as the tiles are laid. In either case the procedure is as shown from 5 onwards.

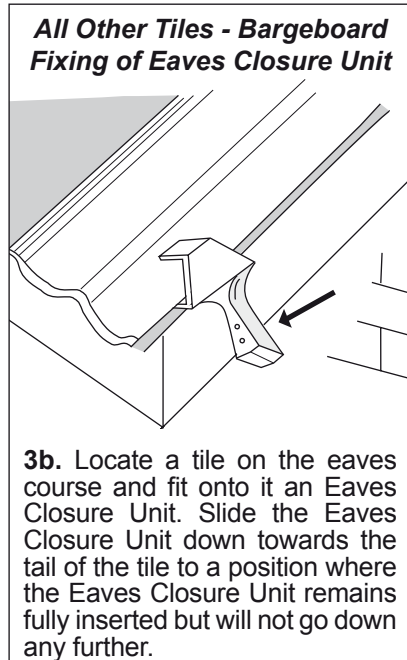

## All Other Tiles - Bargeboard Fixing of Eaves Closure Unit

**3b.** Locate a tile on the eaves course and fit onto it an Eaves Closure Unit. Slide the Eaves Closure Unit down towards the tail of the tile to a position where the Eaves Closure Unit remains fully inserted but will not go down any further.

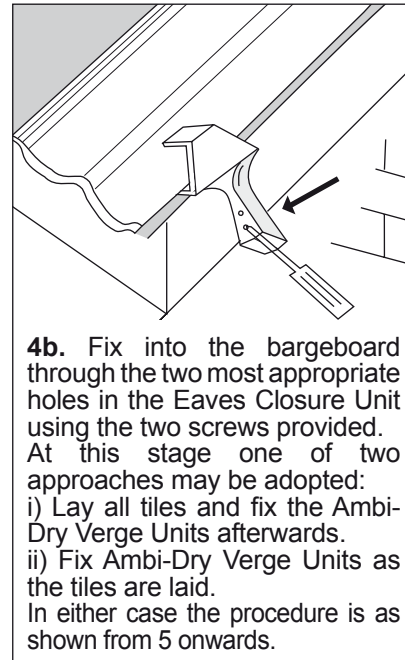

**4b.** Fix into the bargeboard through the two most appropriate holes in the Eaves Closure Unit using the two screws provided. At this stage one of two approaches may be adopted:  
i) Lay all tiles and fix the Ambi-Dry Verge Units afterwards.  
ii) Fix Ambi-Dry Verge Units as the tiles are laid. In either case the procedure is as shown from 5 onwards.

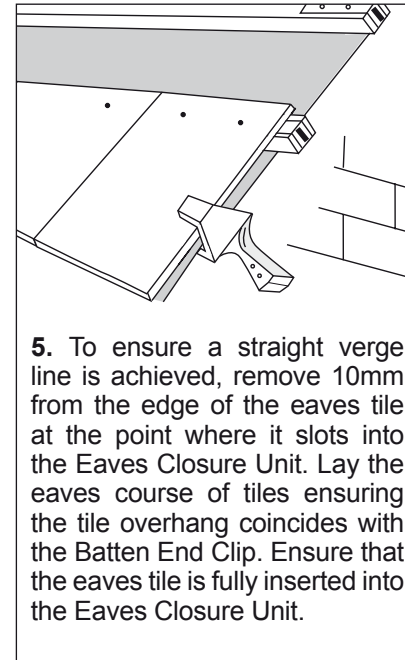

**5.** To ensure a straight verge line is achieved, remove 10mm from the edge of the eaves tile at the point where it slots into the Eaves Closure Unit. Lay the eaves course of tiles ensuring the tile overhang coincides with the Batten End Clip. Ensure that the eaves tile is fully inserted into the Eaves Closure Unit.

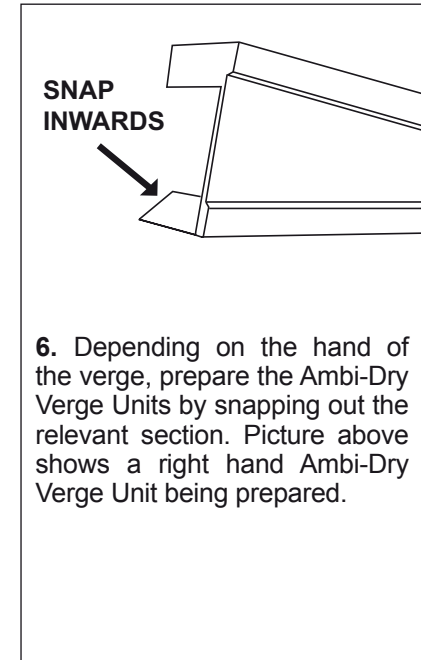

**SNAP INWARDS**

**6.** Depending on the hand of the verge, prepare the Ambi-Dry Verge Units by snapping out the relevant section. Picture above shows a right hand Ambi-Dry Verge Unit being prepared.

\* The interlocks of left hand Mini Stonewold verge tiles must be removed.

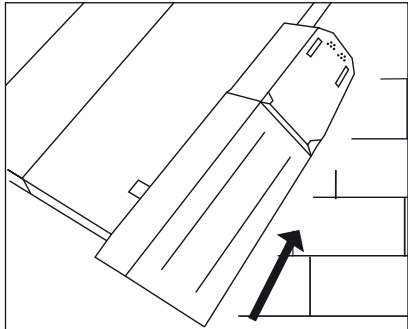

**7.** Clip the first Ambi-Dry Verge Unit over the Eaves Closure Unit. Slide the Ambi-Dry Verge Unit in the direction of the ridge until the tail coincides with the tail of the tile.

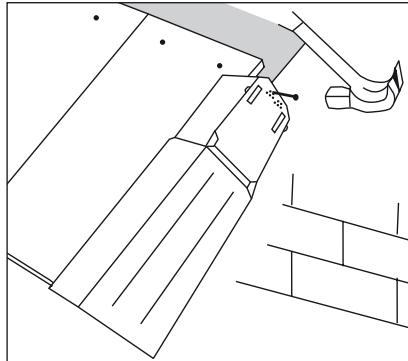

**8.** Ensuring contact with the head of a tile, nail the Ambi-Dry Verge Unit into the Batten End Clip. Nail through the most convenient hole using the 65 x 3.35mm nail provided.

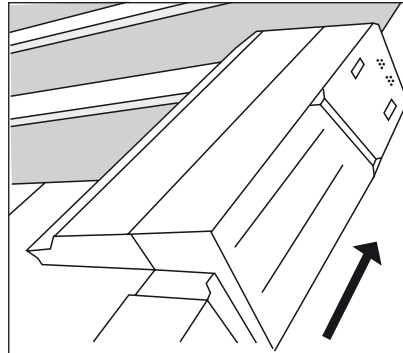

**9.** Carefully locate the second Ambi-Dry Verge Unit in the slots of the first. Slide the Ambi-Dry Verge Unit in the direction of the ridge until the tail coincides with the tail of a tile. Secure the Ambi-Dry Verge Unit to the Batten End Clip as before. Continue in the same manner to the ridge.

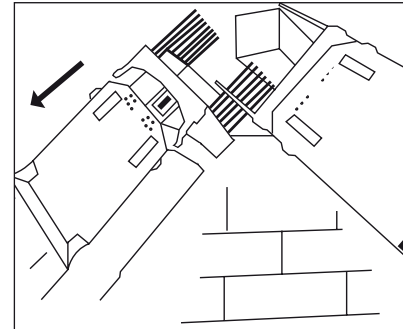

**10.** Before clipping onto the top two Ambi-Dry Verge Units, mesh the Ridge Comb Units together, thus preventing bird access.

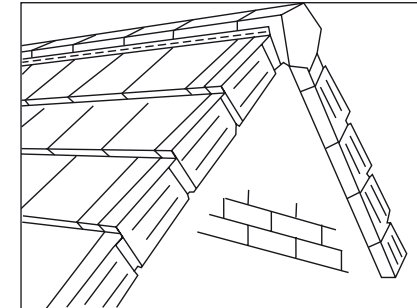

**11.** Complete the ridge/verge junction with a Block-end Ridge Tile.

**Metric Verge Maximum Pitch Table**

	<b>Duo Pitch</b>	<b>Mono Pitch</b>
Landmark Double Pantile	67.5	57.5
Regent	67.5	52.5
Grovebury	67.5	57.5
50 Double Roman	62.5	67.5
Renown	62.5	65
Mini Stonewold	67.5	72.5

There is no maximum pitch on lean-to roofs or where lead roll details are used.